

SUBMITTAL DATA

Flexmaster U.S.A.® SLD-BO3 UT 3000G

SHEET METAL FITTINGS



The Flexmaster U.S.A.® SLD-BO3 UT 3000G fitting is a factory sealed fitting, manufactured from 26 gauge, or heavier, galvanized steel to meet SMACNA and UMC Standards for commercial construction.

The SLD-BO3 UT 3000G is manufactured to provide air-tight installation. It comes with Duro Dyne Open End Bearing and Closed End Bearing, a 2" stool, aluminum rod, and locking quadrant to provide easy access and system balancing when installed in a 1 1/2" thick Insulation Wrapped Duct System.

The SLD-BO3 UT 3000G should be installed using current SMACNA installation standards.

Features

- 26 gauge G90 Galvanized Steel Body
- 24 gauge G90 Galvanized Steel Damper
- Duro Dyne SB138 Open End Bearing and SB 338 Closed End Bearing
- Factory Formed Flange with Double Sided Adhesive Gasket
- Factory Sealed Seams and Duro Dyne Components
- 3/8" Square Aluminum Axle Secured to Damper with U-Bolts
- 2" Insulation Build Out
- Locking Hand Quadrant with Flexmaster U.S.A. Handle

(BO3 Designation consists of 3/8" Aluminum Axle, 2" Build Out and Locking Quadrant)

Order Size	Diameter	Length
6"	5 7/8"	7 1/2"
7"	6 7/8"	7 1/2"
8"	7 7/8"	7 1/2"
9"	8 7/8"	7 1/2"
10"	9 7/8"	7 1/2"
12"	11 7/8"	7 1/2"
14"	13 7/8"	7 1/2"
15"	14 7/8"	7 1/2"
16"	15 7/8"	7 1/2"
18"	17 7/8"	7 1/2"
20"	19 7/8"	7 1/2"

(+/-) 1/8" Tolerance on all Sizes.

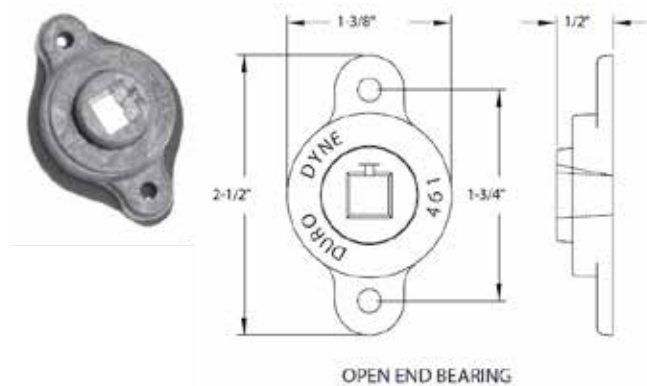
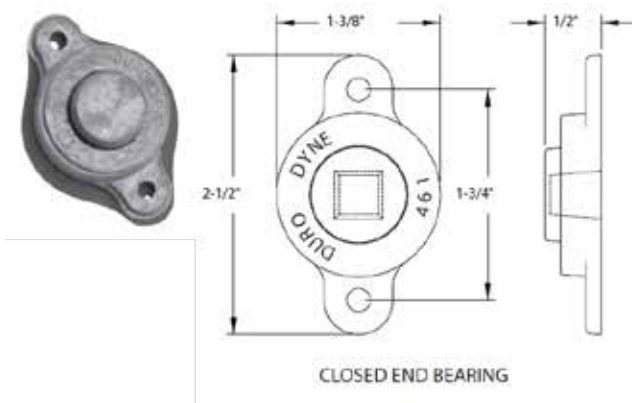

Flexmaster U.S.A.®
 5235 Ted Street
 Houston, TX 77040 USA
 Tel. +1.713.462.7694
 Fax +1.713.939.8441
 www.FlexmasterUSA.com
 www.Masterduct.com

FLEXMASTER U.S.A.®
 A MASTERDUCT COMPANY